

- Approved
- Approved as Noted
- Revise & Resubmit

BY: \_\_\_\_\_

DATE: \_\_\_\_\_

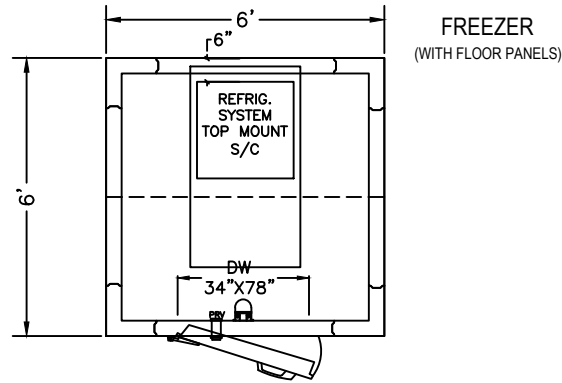

**PLAN VIEW**  
LEFT HINGE

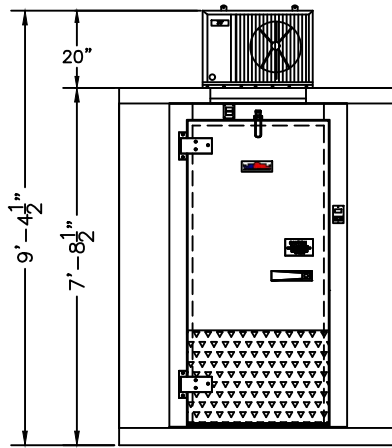

**ELEVATION**  
LEFT HINGE

**REFRIGERATION DESIGN CRITERIA**

ROOM AMBIENT TEMP:	90°F
AT CEILING AMBIENT TEMP:	95°F
PULLDOWN TIME:	24 Hours
HOLDING TEMP:	-10°F
DOOR OPENINGS PER HOUR:	2
INTERIOR/EXTERIOR FINISH	26 GA EMBOSSED GALVANIZED

**REFRIGERATION SPECIFICATIONS**

ELECTRICAL (VOLTS/Hz/PH)	208/230/60/1
AMPS	10.9
WEIGHT (LBS)	220
MATCHING NEMA RECEPTACLE	6-15R



Project: SURVIVOR SERIES

Project #:

Drafter: \_\_\_\_\_ Checker: \_\_\_\_\_

Date: \_\_\_\_\_ Dwg No: \_\_\_\_\_

11/13/2023 6X6 FRZ LH SC

Scale: \_\_\_\_\_ Sheet: \_\_\_\_\_

**As Shown** 1 OF 1

Rev:	A	-	B	-	C	-	D	-	E	-
------	---	---	---	---	---	---	---	---	---	---