

Approved  
 Approved as Noted  
 Revise & Resubmit  
 BY: \_\_\_\_\_  
 DATE: \_\_\_\_\_

# CASING NO FLOOR LHH APPROVAL DRW

APPLICATION	
COOLER CASING DOOR	<input type="checkbox"/>
FREEZER CASING DOOR	<input checked="" type="checkbox"/>

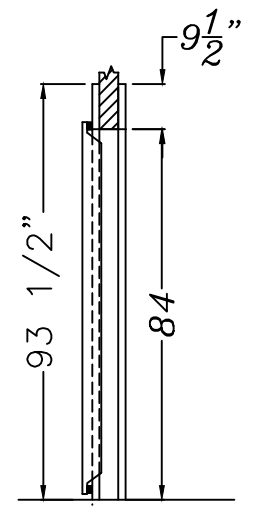
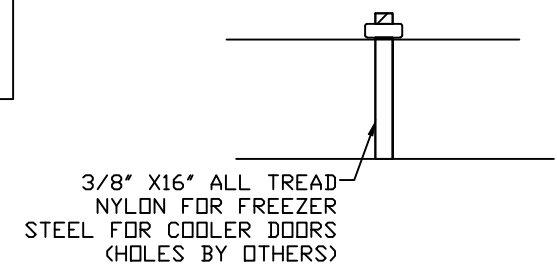
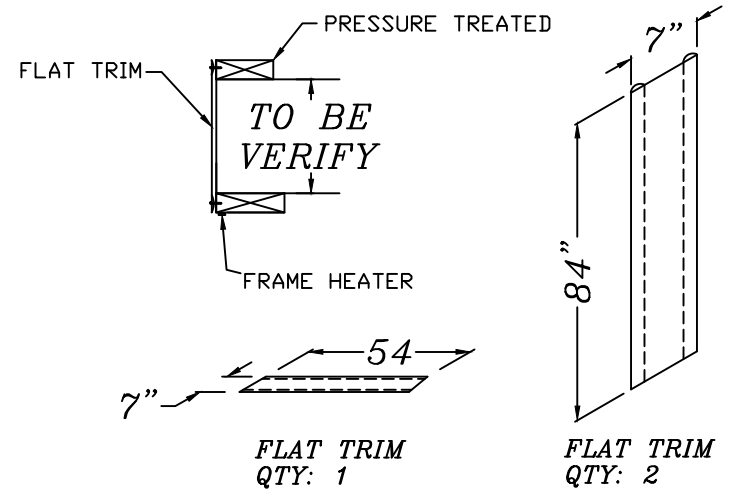

SECTION VIEW

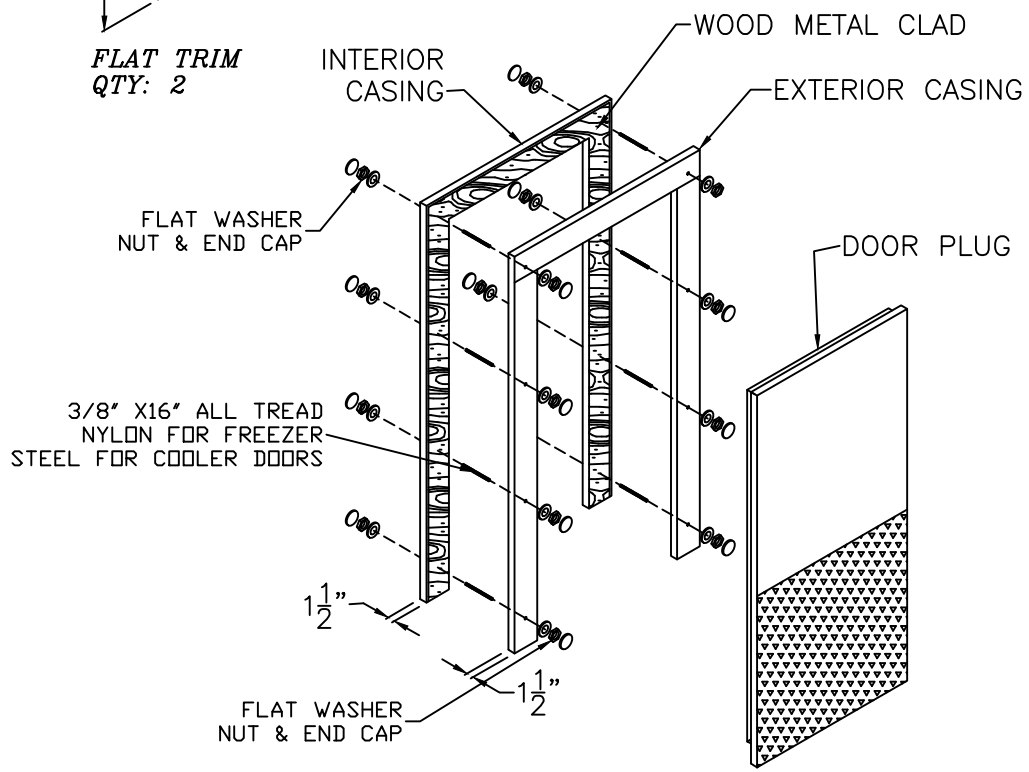

ISOMETRIC CASING DOOR

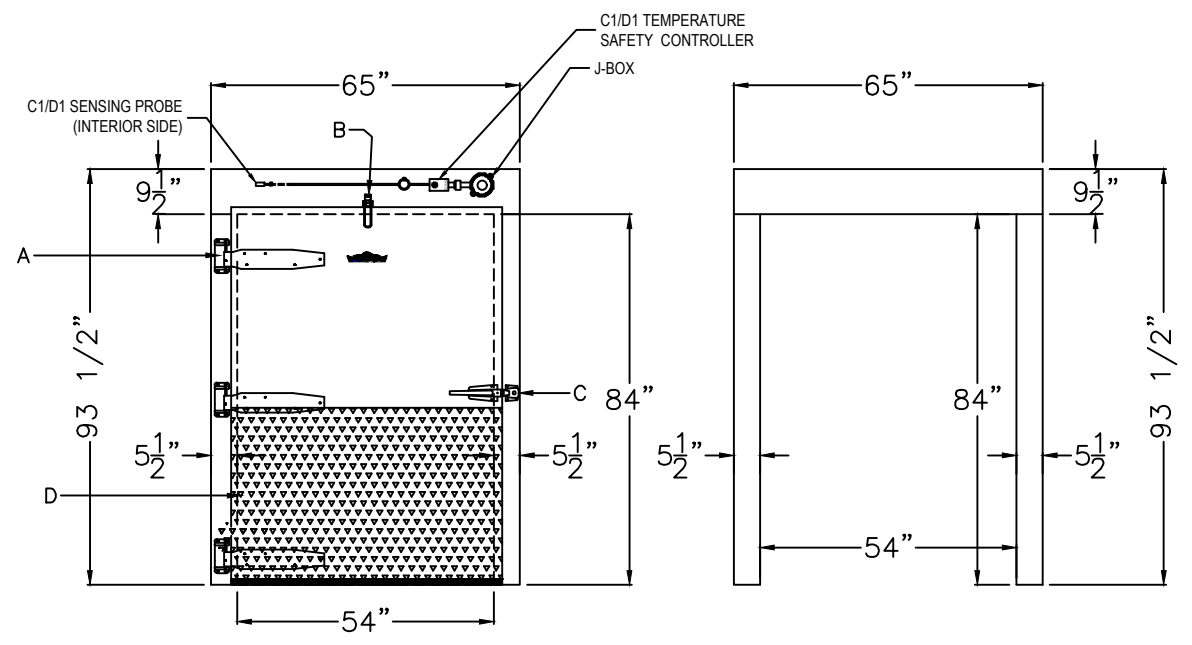

EXTERIOR CASING DOOR

INTERIOR CASING DOOR

- A-HEAVY DUTY HINGE 1277000018
- B-KASON 109400027D DOOR CLOSER
- C-K78CL5020 BROSHEDED CROME LATCH
- D-36" DIAMOND TREAD PLATE INT. & EXT.
- E-1097 SPRING ACTION DOOR CLOSER 1 5/8 OFFSET
- F-RAYCHEM C1/D1 SELF-REGULATING HEAT CABLE 8BTV-1-CT

**INTERIOR FINISH**  
22 GA STAINLESS STEEL

**EXTERIOR FINISH**  
26 GA EMBOSSED GALVANIZED

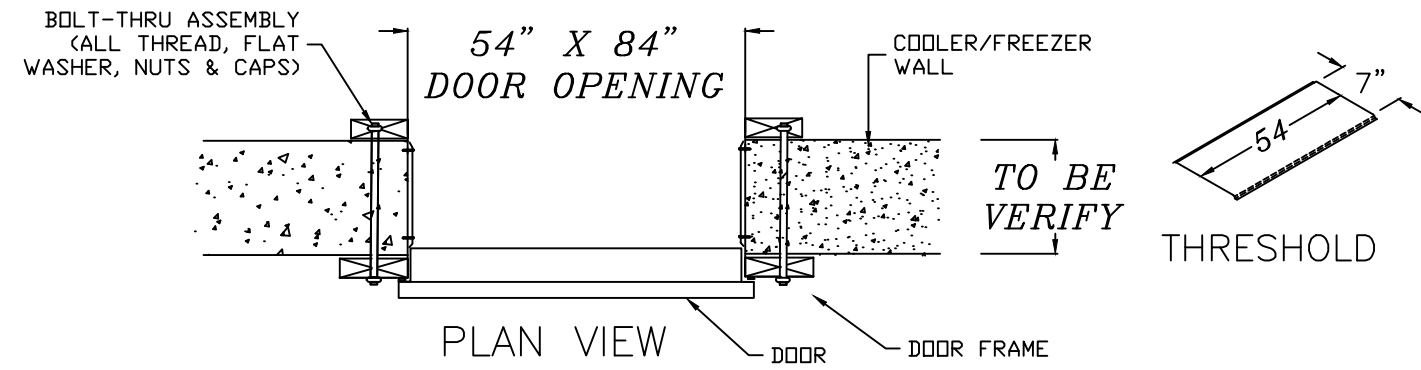

PLAN VIEW



Project: AMERICAN WALK-IN COOLERS	
Project #: 2308-9034	
Drafter: PC	Checker: HA
Date: 11/10/2023	Dwg No: Q13385
Scale:	Sheet:
As Shown	APPROVAL OF 4

Rev:	A	11/13/23 BY RP	B	---	C	---	D	---	E	---
------	---	----------------	---	-----	---	-----	---	-----	---	-----